

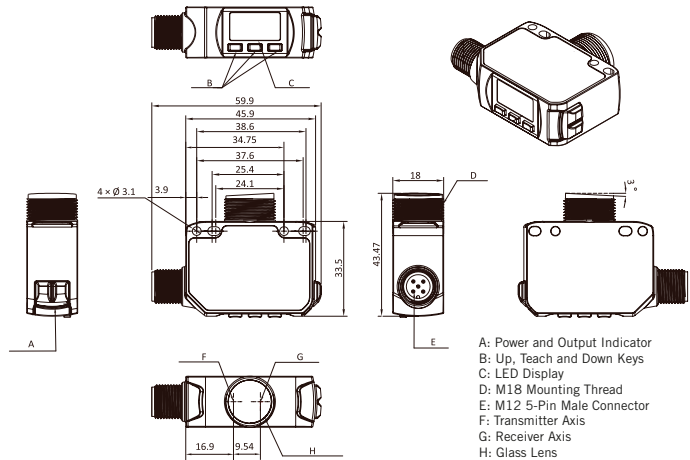

Note: The product images shown may change over time as products are updated.

Dimensions



Part Number

H45-CMOS-0500IOL-SA-M12-5QD

Features

Photoelectric sensors are used in virtually any manufacturing process with moving parts to detect products, machine parts, and a wide variety of moving objects.

For additional information, contact HTM Sensors at 800-644-1756 or service@htmsensors.com

Connection



Serial number	Function	Core color of cable type
1	Power +	BN
2	NPN / PNP	WH
3	Power -	BU
4	IO-Link-DIO; NPN / PNP	BK
5	NC	GY

Technical Data

Sensing Mode	Triangulation
Sensing Range	25-500 mm
Light Source	Red Laser (650nm) Class 1
Light Spot Size	1.5 mm x 3 mm @ 500 mm
Indicator LEDs	Output: Yellow Power: Green
IO-Link	Yes V1.2
Supply Voltage	10-30 V DC
Max. Load Current	<= 100 mA
No Load Current	<= 25 mA
Short Circuit Protection	Yes
Reverse Polarity Protection	Yes
Output Type	PNP/NPN Selectable
Operation Mode	Light On / Dark On Selectable
Switching Frequency	400 Hz
Sensitivity Adjustment	Teachable
Housing Material	Zinc Alloy
Lens Material	Glass
IP Rating	IP67
Timer Options	Yes(On Delay, Off Delay, One Shot)
Ambient Operating Temperature	-10 C to +50 C
Vibration Resistance	EN 60068-2-7
Shock Resistance	EN 60068-2-27
Cable or Connector	M12 A coded 5 Pin

