

H30-RET-8000P-2M

H30 Photoelectric Sensor

Retroreflective



Note: The product images shown may change over time as products are updated.

Diagram

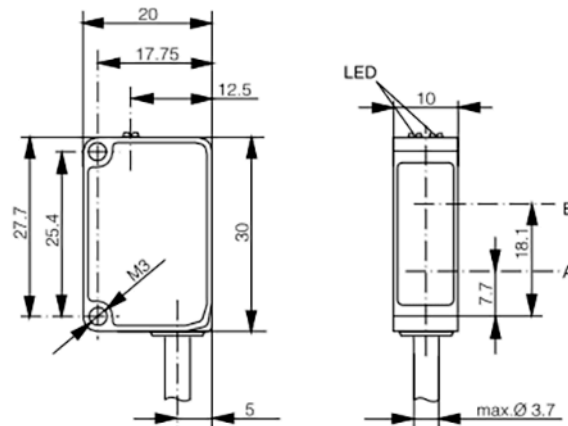

A: emitter axis B: receiver axis

Part Number

H30-RET-8000P-2M

Features

Photoelectric sensors are used in virtually any manufacturing process with moving parts to detect products, machine parts, and a wide variety of moving objects.

For additional information, contact HTM Sensors at 800-644-1756 or service@htmsensors.com

Connection

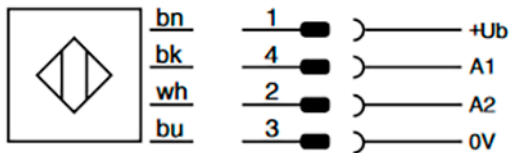

Technical Data

Sensing Range	8 m (*see Note 2)
Light Source	Red LED 630 nm
Light Spot Size	∅ 30 mm @ 1 m / ∅ 140 mm @ 6m
Indicator LEDs	Output:Yellow Excess Gain: Green
IO-Link (*see Note 4)	Yes
Supply Voltage	10-30 V DC
Max. Load Current	<= 100 mA
No Load Current	<=15 mA
Short Circuit Protection	Yes
Reverse Polarity Protection	Yes
Output Type	PNP Complementary
Operation Mode	Light On or Dark on Selectable wiring
Response Time	<= 340us(normal)/<=1ms /<= 100us
Sensitivity Adjustment	-
Housing Material	ABS
Lens Material	PMMA
IP Rating	IP67
Time Options	Selectable via IO-Link
Ambient Operating Temp	-25 C to + 65 C
Vibration Resistance	IEC 60947-5-5
Shock Resistance	IEC 60947-5-5
Cable or Connector	4 Wire 2 m Cable

Note 1: By default, "Normal" mode. "Fine" and "Fast" modes selectable via IO-Link

Note 2: when used with RE-D82

Note 3: Object with 90% reflectance(standard white paper)

Note 4:

IO-Link Verion - V1.0

SIO mode - Supported

Process Data - Detection state & stability alarm

Baudrate - COM2(38.4 kBaud)

Special Functions - Ouput Configuration, Output Timing, Sensor Mode, Detection Counter, Event Flags, Maximum and Actual Sensor Temperature



ECOLAB



In the USA: 1889 Maryland Ave., Niagara Falls, NY 14305
 In Canada: 3419 Mainway, Burlington, ON L7M 1A9
 Toll Free: 1-800-644-1756 • Fax: 888-283-2127
service@htmsensors.com

htmsensors.com