

H30-DIF-1500P-M8-4QD

H30 Photoelectric Sensor

Diffused



Note: The product images shown may change over time as products are updated.

Diagram

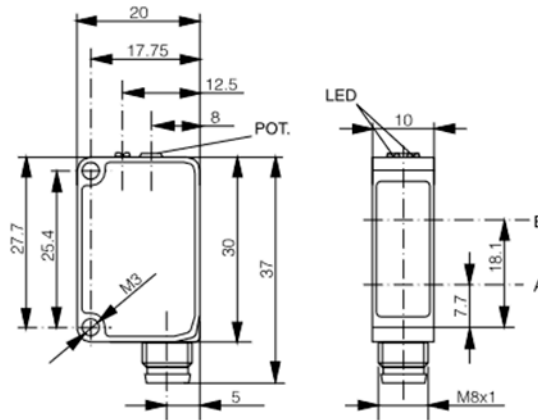

A: emitter axis B: receiver axis

Part Number

H30-DIF-1500P-M8-4QD

Features

Photoelectric sensors are used in virtually any manufacturing process with moving parts to detect products, machine parts, and a wide variety of moving objects.

For additional information, contact HTM Sensors at 800-644-1756 or service@htmsensors.com

Connection



Technical Data

| | |
|-----------------------------|---------------------------------------|
| Sensing Range | 1.5 m (*see Note 3) |
| Light Source | Red LED 630 nm |
| Light Spot Size | ø 15 mm @ 500m / ø 26 mm @ 1 m |
| Indicator LEDs | Output:Yellow Excess Gain: Green |
| IO-Link (*see Note 4) | Yes |
| Supply Voltage | 10-30 V DC |
| Max. Load Current | <= 100 mA |
| No Load Current | <=15 mA |
| Short Circuit Protection | Yes |
| Reverse Polarity Protection | Yes |
| Output Type | PNP Complementary |
| Operation Mode | Light On or Dark on Selectable wiring |
| Response Time | <= 340us(normal)/<=1ms /<= 100us |
| Sensitivity Adjustment | - |
| Housing Material | ABS |
| Lens Material | PMMA |
| IP Rating | IP67 |
| Time Options | Selectable via IO-Link |
| Ambient Operating Temp | -25 C to + 65 C |
| Vibration Resistance | IEC 60947-5-6 |
| Shock Resistance | IEC 60947-5-6 |
| Cable or Connector | 4-Pin M8 Male QD |

Note 1: By default, "Normal" mode. "Fine" and "Fast" modes selectable via IO-Link

Note 2: when used with RE-D82

Note 3: Object with 90% reflectance(standard white paper)

Note 4:

IO-Link Verion - V1.0

SIO mode - Supported

Process Data - Detection state & stability alarm

Baudrate - COM2(38.4 kBaud)

Special Functions - Ouput Configuration, Output Timing, Sensor Mode, Detection Counter, Event Flags, Maximum and Actual Sensor Temperature



In the USA: 1889 Maryland Ave., Niagara Falls, NY 14305
 In Canada: 3419 Mainway, Burlington, ON L7M 1A9
 Toll Free: 1-800-644-1756 • Fax: 888-283-2127
service@htmsensors.com

htmsensors.com